

Colamark



Colamark A202 Sausage Labeling System

The A202 is specially designed for automatic feeding and wrap around labeling, with or without orientation, of cylindrical sausages at high speed. The mechanism of the system is carefully designed to cater for the soft body of the sausages to ensure smooth material handling and wrinkle free labeling.



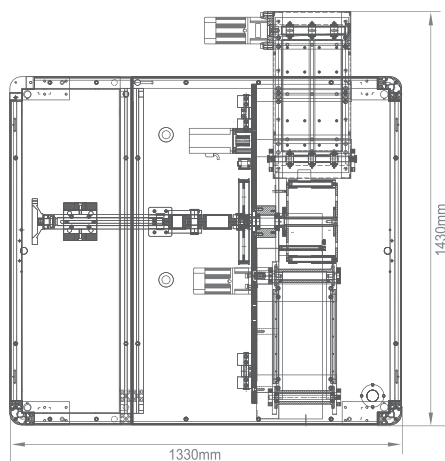
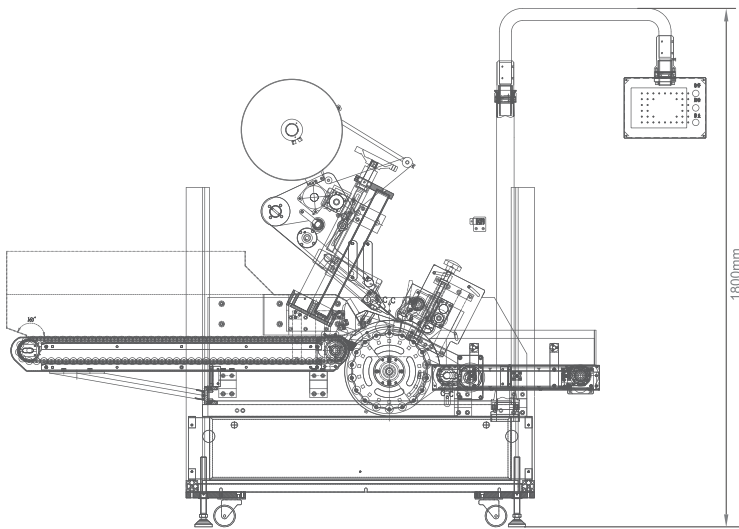

Features

- Flexible material loading and discharge
 - ▶ Hopper feeding, or inline feeding from the upstream equipment
 - ▶ Discharge for manual collection or inline connection to downstream conveyor
 - ▶ Optional exit conveyor with counter to separate discharged sausages into batches of pre-set sizes for subsequent packaging.
- Orientation labeling (intermittent mode): max. output up to 120 ppm (depending on material sizes and orientation mark).
- Non-orientation labeling (continuous mode): maximum output up to 250 ppm (depending on material sizes)
- Optional coding devices for synchronized coding: hot stamping, thermal transfer, ink jet.
- User friendly interface with comprehensive help menus, system status and alert messages.
- Optional full machine enclosure with safety switches

Machine Model	A202
Object size	Cylindrical sausage of diameter 28-69mm
Capacity	80-100 ppm (with orientation) 250 ppm (w/o orientation) (Capacity depends on sizes of materials)
Electricity & power	220V 50/60Hz 1.3kW
Dimensions	(L)2,400×(W)1,340×(H)1,800 mm

(Custom engineered solutions are available to cater for customer's special needs.)

For continuous improvement on design and product innovations, all specification data are subject to change without prior notice

Colamark (Guangzhou) Labeling Equipment Limited

19 Jin Xiu Road, GETDD, Guangzhou, China

Tel: +86 20 8221 6718 Fax: +86 20 8221 5799 PC:510730

Colamark Technologies Limited

820 Topsail Plaza, 11 On Sum Street, Shatin, Hong Kong
Tel: +852 2634 8011 Fax: +852 8161 3311 Email: info@colamark.com Web: www.colamark.com

| HongKong | Guangzhou | Kunming Chengdu | Wuhan | Chongqing | Xian | Shanghai | Qingdao | Beijing | Shenyang | Harbin |